

CONTENTS

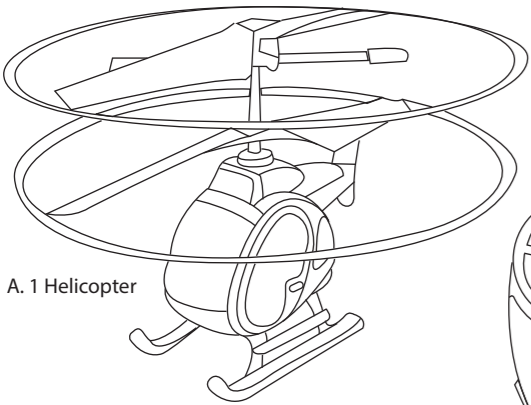

A. 1 Helicopter

Illustrations are for reference only.
Styles may vary from actual contents.

B. 1 Remote Control

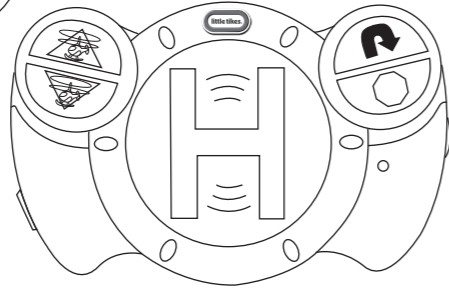

⚠ CAUTION: KEEP FINGERS AWAY FROM SPINNING PROPELLERS

QUICK START

NOTE: Please read all instructions before use and keep this manual for future reference.

- 1) Install 6 AA (LR6) batteries in the remote control.
- 2) Charge the helicopter battery for 30-40 minutes.
- 3) Turn on the helicopter.
- 4) Turn on the remote control and point the receiver on the remote towards the helicopter.
- 5) Use the buttons on the remote control to fly your helicopter in an open, indoor area.

HELICOPTER AND REMOTE CONTROL PARTS

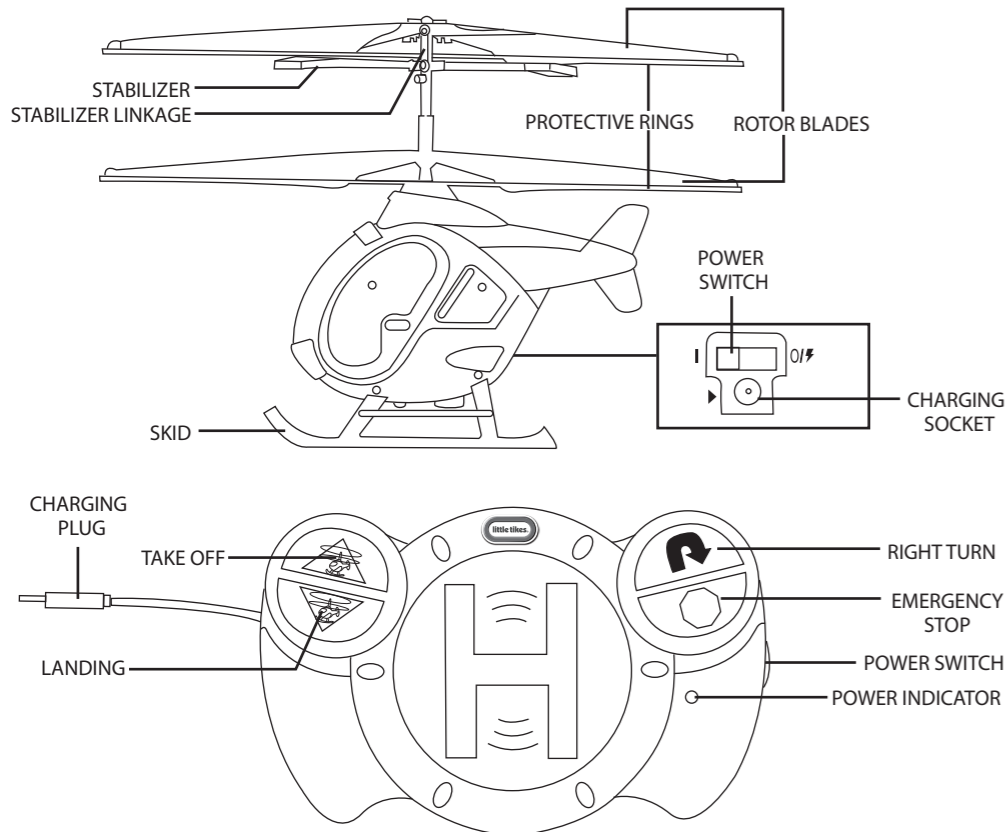

REMOTE CONTROL BATTERY INSTALLATION

Before playing, an adult must install fresh alkaline batteries in the remote control. Here's how:

1. Using a Phillips screwdriver (not included) remove the screw and battery compartment cover from the back of the remote control.
2. Install six (6) fresh 1.5V AA (LR6) alkaline batteries (not included) in the remote control making sure the (+) and (-) ends face the proper direction as indicated inside the battery compartment.
3. Replace the compartment cover and tighten the screw.

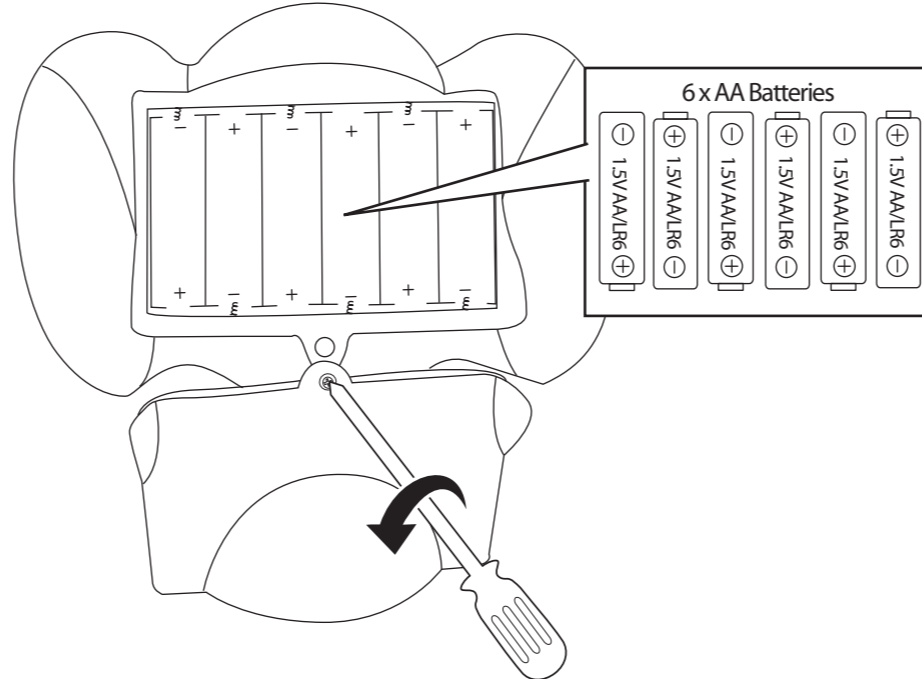

CHARGING THE HELICOPTER

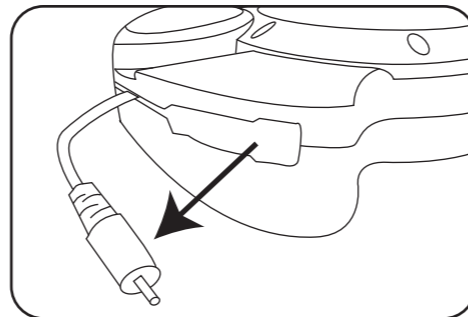

1. Take out the charging cable from the left side of the remote.

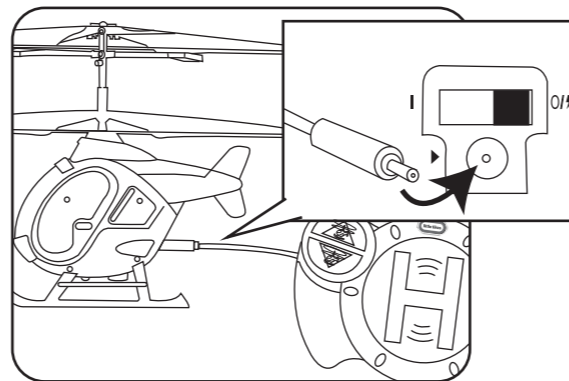

2. Turn the helicopter OFF (O/⚡) and insert the cable into the charging station on the helicopter.

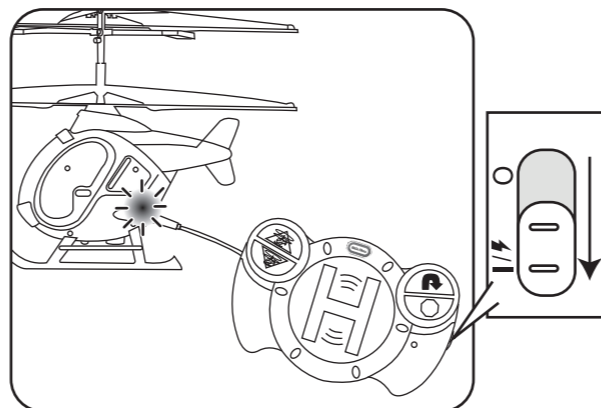

3. Turn ON (I/⚡) the remote control. The charging light on the helicopter will turn green while charging.

4. When the light turns off, the helicopter is fully charged. Unplug the remote control and replace the cord in the unit.

FLYING THE HELICOPTER

Helpful tips for flying:

- If the helicopter crashes, switch the remote control and the helicopter to the OFF positions. Carefully check that no damage was done to the helicopter in the crash before turning the unit on again.
- For best results, use the helicopter away from bright lights to ensure the receiver can detect the remote control.
- Do not cover the receiver on the remote control or on the helicopter.
- Keep the remote control within 15 feet (5 meters) of the helicopter to avoid loss of reception.

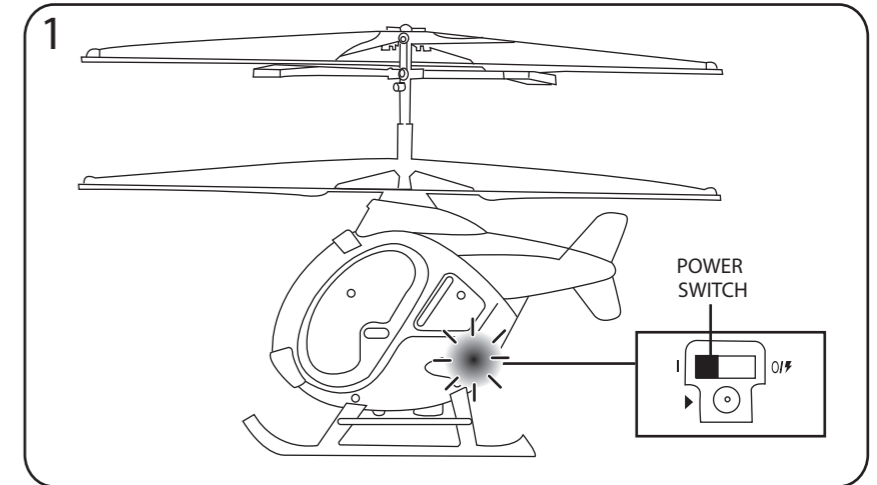

Turn the helicopter to the ON (I) position. The power LEDs will flash.

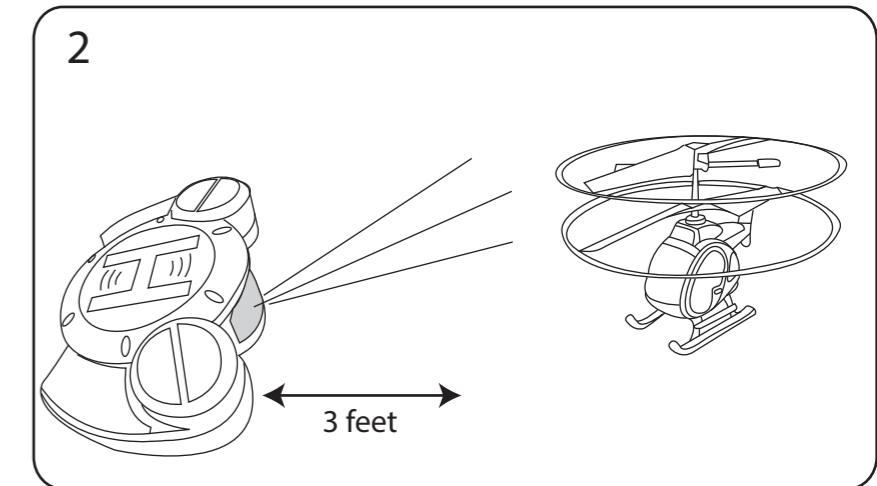

Place the helicopter on a flat, level surface and stand three feet away with the remote control receiver pointing towards the helicopter.

Always keep the receiver on the remote control pointed at the helicopter during flight.

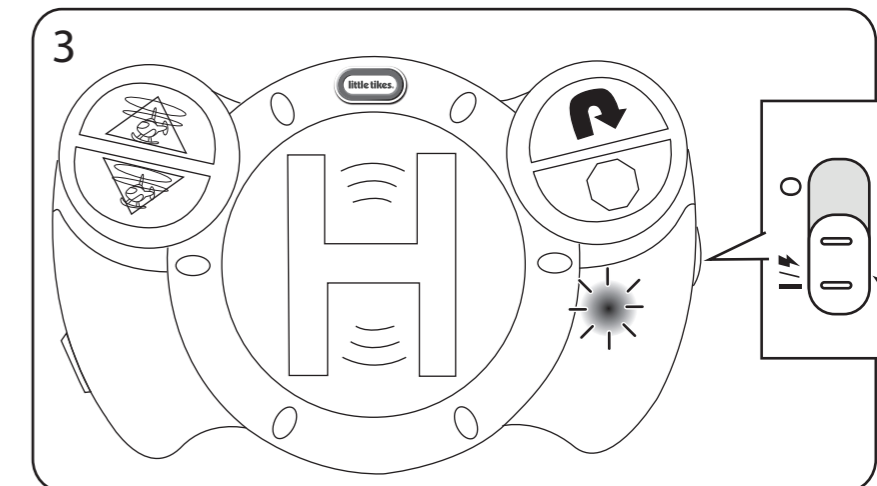

Turn on the remote control by moving the switch on the side to the ON (I/⚡) position. The LED will light up.

FLYING THE HELICOPTER

Remote control buttons only require one touch to operate. Holding buttons continuously can interfere with flying and maneuvering the helicopter.

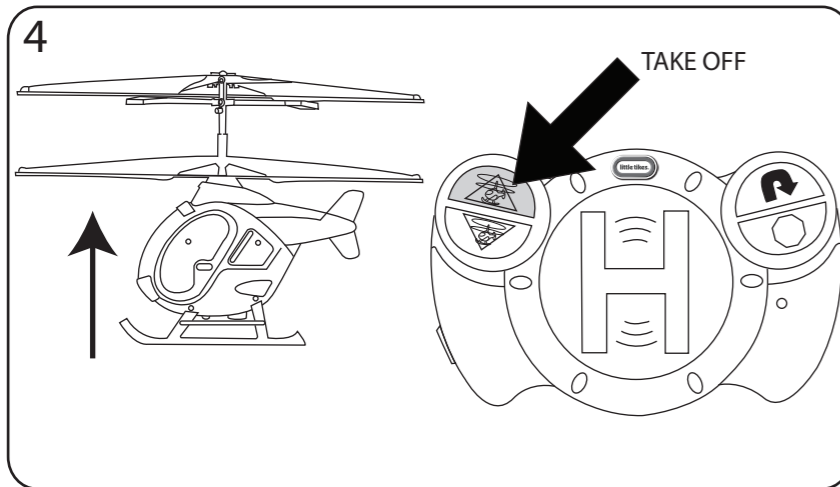

Press the "TAKE OFF" button to make the helicopter fly upward.

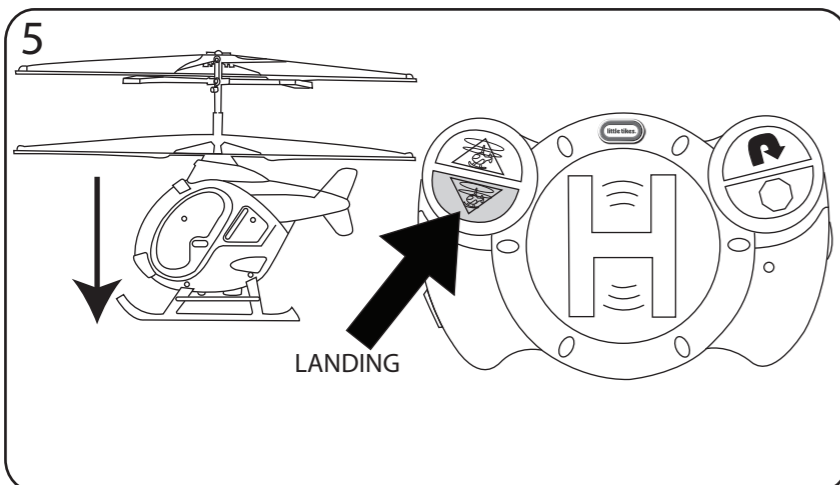

Press the "LANDING" button to make the helicopter fly downward and land.

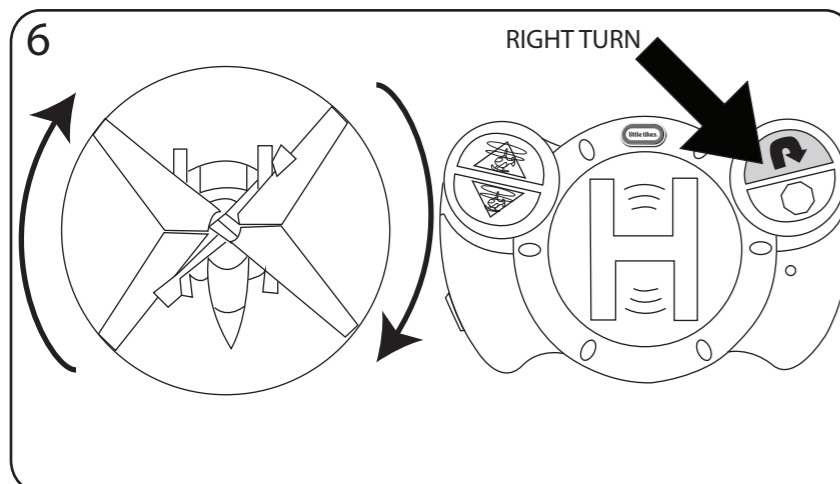

Press the "RIGHT TURN" button to make the helicopter turn clockwise or spin in a circle.

EMERGENCY STOP:

If the helicopter crashes, press the "EMERGENCY STOP" button to stop the propellers. Examine the helicopter for any damage before switching it on and flying again.

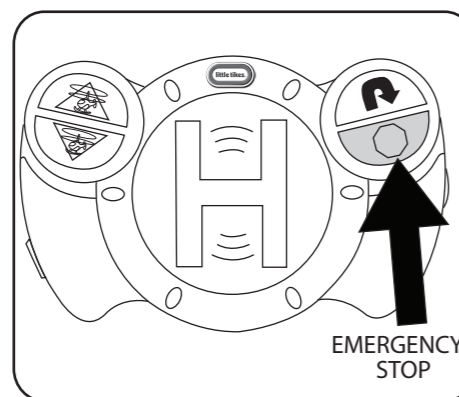

TROUBLESHOOTING

The helicopter does not respond:

- Check that the helicopter and remote control are both turned to the "ON" position.
- The batteries in the remote control may need replacing or the helicopter may need to be recharged.
- The helicopter may have crashed. Press the "EMERGENCY STOP" button or the "LANDING" button one time.

The helicopter suddenly stops and falls to the ground:

- The helicopter may not be picking up signals from the remote control. Point the remote toward the helicopter during use.
- The batteries in the remote control may need replacing or the helicopter may need to be recharged.

The helicopter loses control:

- The helicopter may be picking up signals from another remote control source. Use the helicopter away from other electronic devices, or point the remote control and helicopter in another direction, away from other controllable sources.
- The IR receivers in the helicopter may be affected by bright lights. Only operate the helicopter away from direct lighting. The area should be lit sufficiently to see the helicopter and surrounding objects.
- An object may be blocking the signal between the remote and the helicopter. Make sure there is an open path between the remote control and helicopter at all times.

- The helicopter may be out of range. It has a range of 15 feet (5 meters). Do not operate the helicopter more than 15 feet away from the remote control to avoid crashing and damaging the unit.

The helicopter rotors or other parts have broken or are missing:

- Do not attempt to fly the helicopter with broken or missing parts.

⚠ WARNING:

- Do not touch the running rotors. Keep hands, hair and loose clothing like shoestrings away from moving parts to avoid injury.
- Never hold or throw any objects into the running rotors.
- Risk of eye injuries. Keep a safety distance of at least 3 feet between you and the helicopter.
- Do not fly the helicopter around people or pets.
- Use indoors only. Do not fly the helicopter in the vicinity of water or power lines.
- Do not submerge the helicopter or remote control in water.
- Never make modifications to the product.

IMPORTANT INFORMATION

- Before each use, examine the plug, enclosure, remote and other parts for damage. Never operate this product if it has damaged parts.
- Remote control buttons only require one touch to operate. Holding buttons continuously can interfere with flying and maneuvering the helicopter.
- Flying a helicopter takes skill and should be learned under direct supervision of an experienced adult.
- For best results, use the helicopter in a large, open room without obstacles such as lamps, loose objects, etc.
- Always keep your eyes on the helicopter during use.
- Do not land or crash the helicopter near your head, your body or other people or pets.
- Stand while flying the helicopter to get out of the way quickly if necessary.
- Always switch the helicopter and remote control to the OFF position after use.
- Before recharging, allow the LiPo battery in the helicopter to cool for at least 10 minutes after use.
- Keep the product out of direct sunlight and avoid using in direct heat.
- Wipe the product with a damp cloth to clean. Air dry thoroughly in a well-ventilated area before storing.

LIMITED WARRANTY

The Little Tikes Company makes fun, high quality toys. We warrant to the original purchaser that this product is free of defects in materials or workmanship for 30 days from the date of purchase (dated sales receipt is required for proof of purchase). At the sole election of The Little Tikes Company, the only remedies available under this warranty will be the replacement of the defective part or replacement of the product. This warranty is valid only if the product has been assembled and maintained per the instructions. This warranty does not cover abuse, accident, cosmetic issues such as fading or scratches from normal wear, or any other cause not arising from defects in material and workmanship. U.S.A and Canada: For warranty service or replacement part information, please visit our website at www.littletikes.com, call 1-800-321-0183 or write to: Consumer Service, The Little Tikes Company, 2180 Barlow Road, Hudson OH 44236, U.S.A. Some replacement parts may be available for purchase after warranty expires—contact us for details. Outside U.S.A and Canada: Contact place of purchase for warranty service. This warranty gives you specific legal rights, and you may also have other rights, which vary from country/state to country/state. Some countries/states do not allow the exclusion or limitation of incidental or consequential damages, so the above limitation or exclusion may not apply to you.

LiPo BATTERY INFORMATION

This helicopter is equipped with a LiPo rechargeable battery. Please pay attention to the following cautions for safety use:

- Before recharging, allow the LiPo battery in the helicopter to cool for at least 10 minutes after use.
- Do not dispose of the battery in fire or extreme heat.
- Do not use or leave the battery near a heat source such as a fire or a heater.
- Do not strike or throw the battery against hard surfaces.
- Do not immerse the battery in water, and keep the battery in a cool, dry place.
- When recharging, only use the battery charger specifically included for that purpose.
- Do not over-charge the battery.
- Do not connect the battery to an electrical outlet.
- Do not directly solder the battery and pierce the battery with a nail or other sharp object.
- Do not disassemble or alter the battery.
- Charge the battery every 6 months and as necessary.
- Do not transport or store the battery with metal objects such as necklaces, hairpins, etc.
- Please recycle a used battery after covering the battery terminals with insulation tape or inserting it into an individual poly bag.
- Battery inside the helicopter is not replaceable.

Note:

- Under the environment with electrostatic discharge, the product may malfunction and require the user to reset the product.
- New alkaline batteries are recommended to use in the remote control to obtain best and maximum performance.
- This product must only be used with the recommended charger.

ALKALINE BATTERY SAFETY INFORMATION

- Charging of rechargeable batteries should only be done under adult supervision. Use only size "AA" (LR6) alkaline batteries (6 required).
- Never mix old batteries with new batteries, rechargeable (nickel-cadmium) or carbon zinc with alkaline batteries.
- Be sure to insert the batteries correctly and follow the toy and battery manufacturer's instruction.
- Always remove exhausted or dead batteries from the product.
- Dispose of dead batteries properly; do not burn or bury them.
- Do not attempt to recharge non-rechargeable batteries.
- Remove rechargeable batteries from the product before recharging.
- Charging of rechargeable batteries should only be done under adult supervision with batteries removed from product.
- Avoid short-circuiting battery terminals.
- Remove batteries before placing the unit into storage for a prolonged period of time.

FCC COMPLIANCE

NOTE: This equipment has been tested and found to comply with the limits for a Class B digital device, pursuant to Part 15 of the FCC Rules. These limits are designed to provide reasonable protection against harmful interference in a residential installation. This equipment generates, uses and can radiate radio frequency energy and, if not installed and used in accordance with the instructions, may cause harmful interference to radio communications. However, there is no guarantee that interference will not occur in a particular installation. If this equipment does cause harmful interference to radio or television reception, which can be determined by turning the equipment off and on, the user is encouraged to try to correct the interference by one or more of the following measures:

- Reorient or relocate the receiving antenna.
- Increase the separation between the equipment and receiver.
- Connect the equipment into an outlet on a circuit different from that to which the receiver is connected.
- Consult the dealer or an experienced radio/TV technician for help.

This device complies with Part 15 of the FCC Rules. Operation is subject to the following two conditions: (1) This device may not cause harmful interference, and (2) this device must accept any interference received, including interference that may cause undesired operation.

Caution: Modifications not authorized by the manufacturer may void users authority to operate this device. CAN ICES-3 (B)/NMB-3(B).



'Let's care for the environment!'

The wheelie bin symbol indicates that the product must not be disposed of with other household waste. Please use designated collection points or recycling facilities when disposing of the item. Do not treat old batteries as household waste. Take them to a designated recycling facility.

Please keep this manual as it contains important information.



© The Little Tikes Company, an MGA Entertainment company. LITTLE TIKES® is a trademark of Little Tikes in the U.S. and other countries. All logos, names, characters, likenesses, images, slogans, and packaging appearance are the property of Little Tikes. Little Tikes Consumer Service 2180 Barlow Road Hudson, Ohio 44236 U.S.A. 1-800-321-0183 Printed in China

MGA Entertainment UK Ltd 50 Presley Way Crownhill Milton Keynes MK8 0ES Bucks, UK 0800 521 558 www.littletikes.com www.littletikes.co.uk



Visit our website at www.littletikes.com to register your product and to enter our sweepstakes. (No purchase necessary)

0718-0-E/INT